



PRODUCT SPECIFICATION

产品规范

适用于 For
K827 GNSS 板卡
K827 GNSS Board



©2023, QinNav Technology Ltd. All rights reserved. QinNav is the trademark of QinNav Technology Ltd. registered in People's Republic of China. All other trademarks are the property of their respective owners.

REVISION HISTORY / 修订历史

Revision/版本	Modification/更改	Date/日期
1.0	New Release / 新发	2023/9/19

DIRETORY / 目录

REVISION HISTORY / 修订历史.....	2
DIRETORY / 目录.....	3
1. Introduction / 简介.....	4
1.1. Product Characteristics / 产品特性.....	4
2. Size / 尺寸.....	9
3. Pin Arrangement and Definition / 针脚标识和定义.....	10
3.1. Remarks / 说明.....	11
4. Application Connection Example / 应用连接示例.....	15
5. Package / 包装.....	18
Figures	
Figure 1. K827 Product Photo / K827 实物图.....	9
Figure 2. K827 Dimension View / K827 三视图.....	9
Figure 3. K827 Includes 28 Pin / K827 包括28Pin.....	10
Figure 4. Connections between RS232 COM1, 2, 3 of K827 and Some Other Devices with An UART / K827 RS232 COM1、2、3与其他使用UART接口的设备之间的连接示意.....	15
Figure 5. Minimum Hardware Design of K827 / K827 最小硬件设计.....	16
Figure 6. Recommend Design of K827 / K827 推荐硬件设计.....	17
Tables	
Table 1. Product Characteristics / 产品特性.....	4
Table 2. Pin Definition of K827 28 Pin / K827 28Pin针脚定义.....	10
Table 3. LVCMOS 3.3V Electrical Standard / LVCMOS 3.3V电气标准.....	11
Table 4. LVTTTL 3.3V Electrical Standard / LVTTTL 3.3V电气标准.....	12
Table 5. K827 Package Description / K827 包装说明.....	18

1. Introduction / 简介

K827 GNSS is a full-system and full-frequency RTK positioning and heading board developed by Shanghai QinNav Technology Co., Ltd. based on Quantum III Soc with fully independent intellectual property rights. It supports BDS-2, BDS-3, GPS, GLONASS, Galileo, QZSS, IRNSS and other satellite system signals, contains onboard IMU, supports integrated navigation and is suitable for surveying and mapping, robotics, foundation enhancement and other fields.

K827 GNSS是上海钦天导航技术有限公司基于具有完全自主知识产权的Quantum III开发的全系统全频点RTK定位定向板卡，支持BDS-2、BDS-3、GPS、GLONASS、Galileo、QZSS、IRNSS等卫星系统信号跟踪，板载IMU，支持组合导航，适用于测量测绘、机器人、地基增强等领域。

1.1. Product Characteristics / 产品特性

Table 1. Product Characteristics / 产品特性

Characteristics	K827	
Signals 信号	Positioning & Heading 定位&定向	GPS: L1C/A, L2P, L2C, L5, L1C
		BDS-2: B1I, B2I, B3I
		BDS-3: B1I, B3I, B1C, B2a, B2b
		GLONASS: G1, G2, G3*
		Galileo: E1, E5b, E5a, E5 AltBoC*, E6c*
		QZSS*: L1C/A, L2C, L5, L1C
		SBAS*: L1C/A, L5
		IRNSS*: L5
Items with * will be adjusted with the version. 带*项会随同版本进行调整。		
Time to First Fix 首次定位时间	Cold Start 冷启动	<20s (Adding Acceleration Capture Module,增加捕获加速模块)
	Hot Start (with RTC)	<10s (Typical,典型)

	热启动 (使用RTC)	
Signal Capture 信号捕获	Reacquisition 失锁重捕	<1s
	Signals Tracking Sensitivity 信号跟踪灵敏度	-155dBm
	Signal Capture Sensitivity 信号捕获灵敏度	-138dBm
Measurement Precision 测量准确度	Pseudo-range Precision 伪距精度	≤10cm
	Carrier Phase Precision 载波相位精度	≤1mm
Accuracy 精度	PPS (RMS) 授时精度	20ns
	SPP Accuracy 标准单点定位精度	H≤1.5m, V≤3m (1σ, PDOP≤4)
	Static Differential Accuracy (Supported by Compass Solution) 静态差分精度 (Compass Solution软件支持)	H:±(2.5+1×10 ⁻⁶ ×D)mm V:±(5.0+1×10 ⁻⁶ ×D)mm D为基线长度 (单位: mm) D-Baseline length (Unit: mm)
	Speed Accuracy 测速精度	≤0.02m/s (1σ, PDOP≤4)
PPP	PPP Convergence Time PPP初始化时间	<15min

	PPP Accuracy PPP精度	H≤10cm, V≤20cm
RTK	RTK Initialization Time RTK初始化时间	<5s (D<10km)
	Initialization Reliability 初始化置信度	>99.9%
	RTK Accuracy RTK精度	H:±(8+10 ⁻⁶ ×D)mm V:±(15+10 ⁻⁶ ×D)mm D为基线长度(单位: mm) D-Baseline length (Unit: mm)
Attitude Accuracy 测姿精度	Azimuth Accuracy 方位角精度	(0.15/R)°, R is baseline length in meter. R为基线长度, 单位为米
	Roll or Pitch Accuracy 横滚或俯仰角	(0.25/R)°, R is baseline length in meter. R为基线长度, 单位为米
Anti-interference 抗干扰	K827 is built-in narrowband and continuous wave suppression algorithm engine K827 内置窄带和连续波抑制算法引擎	
Inertial Navigation 组合导航	While the GNSS antenna signal is losing lock for 3 seconds, the accuracy maintains at centimeter level. While the GNSS antenna signal is losing lock for 10 seconds, the accuracy maintains at meter level. GNSS天线信号失锁 3s, 精度保持cm级 GNSS天线信号失锁 10s, 精度保持m级	
IMU	Gyroscope 陀螺仪	Measurement ranges 量程: ±125°/s
		Zero-biased stability

		零偏稳定性: 10°/h
		Angular random walk 角度随机游走: 0.3°/sqrt(h)
	Accelerometer 加速度计	Measurement ranges 量程: ±4g
		Bias instability 零偏稳定性: 70ug
		Velocity random walk 速度随机游走: 0.16m/s/sqrt(h)
Data Rates 数据速率	Measurements & Position 测量&定位	Max 20Hz (Optional, 选配项)
	RTK: Positioning RTK: 定位	Max 20Hz (Optional, 选配项)
	IMU	Max 50Hz (Optional, 选配项)
Data Formats 输出数据格式	NMEA-0183	GPGGA, GPGSV, GPGLL, GPGSA, GPGST, GPHDT, GPRMC, GPVTG, GPZDA etc.
	ComNav Binary (CNB) 司南二进制格式	ComNav Self-Defined Binary 司南自定义二进制
	CMR(GPS)	CMROBS, CMRREF
	RTCM2.X	RTCM1, RTCM3, RTCM31
	RTCM3.X	1004~1008,1012,1019,1020,1033,1042,1045/1046, 1230 MSM3~MSM7:1073~1077,1083~1087,1123~1127,1093~1097

©2023, QinNav Technology Ltd. All rights reserved. QinNav is the trademark of QinNav Technology Ltd., registered in People's Republic of China. All other trademarks are the property of their respective owners.

Electrical 电气特性	Voltage 供电电压	+ 3.3V~3.45V DC
	Power Consumption 功耗	2.0W
Environmental 环境要求	Operating Temperature 工作温度	-40°C~+85°C
	Storage Temperature 储存温度	-55°C~+95°C
Antenna Interface 天线接口	Impedance Matching 阻抗匹配	50Ω
	Antenna Power 天线供电电压	External 外部供电: +3.3V~+5V @ (0-100) mA
	Antenna Gain 天线增益	20~35dB
Hardware Interface 硬件接口	UARTx2 , UART/USBx1 , PPSx1 , EVENTx2 , SPIx1	
Physical 物理参数	Size 尺寸	45.7mm×71.1mm×9.15mm
	Weight 重量	20.6g
	Package 封装	28PIN

2. Size / 尺寸

In this section, product photo, three-side views and the dimension of K827 is provided for customers' further hardware design and installation.

本节提供了K827的实物图，三视图和对应的物理尺寸，便于用户进一步系统硬件设计和安装。



Figure 1. K827 Product Photo / K827 实物图

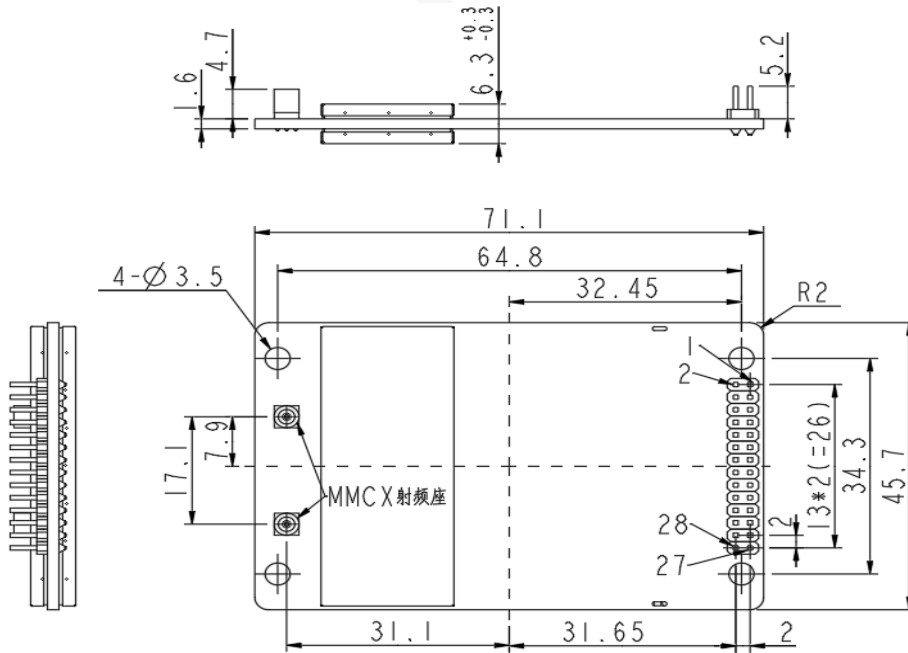

Figure 2. K827 Dimension View / K827 三视图

3. Pin Arrangement and Definition / 针脚标识和定义

K827 GNSS board includes 28Pin.

K827GNSS板卡包括28Pin。

1	RSV	RSV	2
3	SPI_CLK	SPI_CS	4
5	LNA_PWR	VIN	6
7	RSV	COM3_RX	8
9	SYS_RSTn	VARF	10
11	EVENT2	LED_RTK	12
13	COM3_TX/EVENT1	GND	14
15	COM1_TX	COM1_RX	16
17	GND	COM2_TX	18
19	COM2_RX	GND	20
21	PV	GND	22
23	PPS	LED_SAT	24
25	SPI_MISO	SPI_MOSI	26
27	RSV	RSV	28

Figure 3. K827 Includes 28 Pin / K827 包括28Pin

Table 2. Pin Definition of K827 28 Pin / K827 28Pin针脚定义

Pin	Signal	Type	Description	
1~2	RSV	/	Reserve (Float)	保留管脚 (悬空)
3	SPI_CLK	I/O	SPI CLK	SPI总线时钟信号
4	SPI_CS	I/O	SPI CS	SPI总线片选信号
5	LNA_PWR	PWR (I)	Power Supply for External Antenna LNA	天线供电电源
6	VIN	PWR	DC Power Supply for Card	板卡供电电源
7	RSV	/	Reserve (Float)	保留管脚 (悬空)
8	COM3_RX	I	Received Data for COM3 Input	串口3输入信号

©2023, QinNav Technology Ltd. All rights reserved. QinNav is the trademark of QinNav Technology Ltd., registered in People's Republic of China. All other trademarks are the property of their respective owners.

Pin	Signal	Type	Description	
9	SYS_RSTn	I	System Reset	系统复位信号
10	VARF	O	Square Wave Output	方波输出
11	EVENT2	I	Event2 Mark	外部事件2输入
12	LED_RTK	O	RTK Data LED Indicator	在接收或发送差分信号时会输出高电平脉冲，其他状态输出低电平
13	COM3_TX/ EVENT1	Multipl exed	Transmitted Data for COM3 Output /Event1 Mark Default: UART3 TX	串口3输出信号/外部事件1输入 默认状态：串口3输出信号
14	GND	GND	Ground Reference	参考地
15	COM1_TX	O	Transmitted Data for COM1 Output	串口1输出信号
16	COM1_RX	I	Received Data for COM1 Input	串口1输入信号
17	GND	GND	Ground Reference	参考地
18	COM2_TX	O	Transmitted Data for COM 2 output	串口2输出信号
19	COM2_RX	I	Received Data for COM 2 input	串口2输入信号
20	GND	GND	Ground Reference	参考地
21	PV	O	Output Indicates Valid GPS Position when High	位置有效指示信号
22	GND	GND	Ground Reference	参考地
23	PPS	O	Pulse Output Synchronized to OEM Time	同步卫星时间脉冲
24	LED_SAT	O	Tracked Satellite Number Indicator	搜星时，模块搜星数与高电平脉冲数 一致；不搜星时，5S输出一次高电平
25	SPI_MISO	I/O	SPI MISO	SPI主输入从输出信号
26	SPI_MOSI	I/O	SPI MOSI	SPI主输出从输入信号
27~28	RSV	/	Reserve (Float)	保留管脚（悬空）
Items with * will be adjusted with the version. 带*项会随同版本进行调整。				

3.1. Remarks / 说明

1. Electrical Characteristics / 电气特性

COM1/2/3(TX&RX), SPI, LED_STAT/RTK, PV, RTS_SYS, PPS, EVENT1 and EVENT2 are LVCMOS 3.3V level, All these signals are LVCMOS/LVTTL 3.3V compatible.

COM1/2/3 (TX&RX) , SPI, LED_STAT/RTK, PV, RTS_SYS, PPS, EVENT1和EVENT2为LVCMOS 3.3V 电平，所有这些信号均兼容LVCMOS / LVTTL 3.3V。

Table 3. LVCMOS 3.3V Electrical Standard / LVCMOS 3.3V电气标准

Symbols 符号	Description 描述	Min 最小	Max 最大
------------	----------------	--------	--------

©2023, QinNav Technology Ltd. All rights reserved. QinNav is the trademark of QinNav Technology Ltd., registered in People's Republic of China. All other trademarks are the property of their respective owners.

V_{IH}	Input high voltage 输入高电压	2.0V	VCC+0.3V
V_{IL}	Input low voltage 输入低电压	-0.3V	0.8V
V_{OH}	High-level output voltage 高电平输出电压	VCC-0.4V	--
V_{OL}	Low-level output voltage 低电平输出电压	--	0.41V
I_{OH}	Sourcing current 拉电流		8mA
I_{OL}	Sinking current 灌电流		8mA

Table 4. LVTTTL 3.3V Electrical Standard / LVTTTL 3.3V电气标准

Symbols 符号	Description 描述	Min 最小	Max 最大
V_{IH}	Input high voltage 输入高电压	2.0V	VCC+0.3V
V_{IL}	Input low voltage 输入低电压	-0.3V	0.8V
V_{OH}	High-level output voltage 高电平输出电压	VCC-0.4V	--
V_{OL}	Low-level output voltage 低电平输出电压	--	0.41V
I_{OH}	Sourcing current 拉电流		8mA
I_{OL}	Sinking current 灌电流		8mA

2. Can withstand Voltage Range / 能承受的电压范围

The signal with the maximum voltage range from -0.3V to 3.6V is as follows: COM1/2/3(TX&RX), SPI, LED_STAT/RTK, PV, RTS_SYS, PPS, EVENT1 and EVENT2.

所能承受电压的最大值范围是-0.3V~3.6V的信号如下：COM1/2/3（TX&RX），SPI，LED_STAT/RTK，PV，RTS_SYS，PPS，EVENT1和EVENT2。

3. Supply Voltage / 供电电压

VIN main power supply, voltage range: 3.3V~3.45V (DC), voltage ripple and spikes require less than 50mV. K827: LNA_PWR, voltage range: 3.3V ~ 5.5V (DC), voltage ripple and spikes require less than 50mV.

VIN主供电电源，电压范围：3.3V~3.45V（直流），电压纹波和尖峰脉冲要求小于50mV。K827: LNA_PWR，电

压范围：3.3V~5.5V（直流），电压纹波和尖峰脉冲要求小于50mV。

4. Add Surge Protection / 增加浪涌保护

In order to effectively protect against lightning strikes and surges, and prevent damage to the feed current limiting chip inside the module, it is recommended that users supply power to the antenna from outside the module and increase the surge protection function.

If you need to feed the antenna from the outside, it is recommended to use a high-voltage, high-power feeder chip; or add high-power protection devices such as gas discharge tubes, varistors, and TVS tubes to the feeder circuit.

为了有效防雷击、防浪涌，防止模块内部的馈电限流芯片损坏，建议用户从模块外部给天线供电并增加浪涌保护功能。

如需从外部为天线馈电，建议选用高耐压、大功率的馈电芯片；或在馈电电路上增设气体放电管、压敏电阻、TVS管等大功率的防护器件。

5. Hardware Integration Considerations / 硬件集成注意事项

- 1) VCC power-on has a good monotonicity, and the initial level is lower than 0.4V, and the upstroke and ringing are guaranteed within the range of 5% VCC;
- 2) Use the VCC pin to provide a reliable power supply and all GND pins of the module are grounded;
- 3) The LNA_PWR pin is connected to +3.3~5.5V voltage;
- 4) The module reset pin RTS_SYS is for restoring the factory settings of the module. Please connect it correctly to ensure that the module can be reset reliably;
- 5) Special attention should be paid to:
Power supply: The guarantee of stable and low ripple power supply, the peak-to-peak value of the ripple voltage is preferably not higher than 50mVpp. It is recommended to use a power chip with a current output capacity greater than 2A to supply power to the module.
In addition to using LDO to ensure the power supply is pure, it is also necessary to consider:
 - ①. Widening the power traces or using split copper surfaces to transmit current;
 - ②. Place the LDO as close to the module as possible in the layout;
 - ③. Avoid the power traces passing through high power with high inductance devices such as magnetic coils.
- 6) Antenna interface: The antenna line is as short and smooth as possible, avoiding acute angles; pay attention to 50Ω impedance matching;
- 7) Avoid wiring directly under K827;
- 8) The module is as far away from the high temperature airflow as possible.

- 1) VCC上电具有良好的单调性，且起始电平低于0.4V，上冲与振铃保障在5%VCC范围内；
- 2) 用VCC引脚提供可靠的电源且模块所有GND引脚接地；
- 3) LNA_PWR脚接入+3.3~5.5V电压；
- 4) 模块复位引脚RTS_SYS为恢复模块出厂设置，请正确连接以保证模块可以可靠复位；
- 5) 在设计中应特别注意：

供电：稳定及低纹波电源的保证，纹波电压峰值最好不高于50mVpp。建议采用电流输出能力大于2A的电源

芯片给模块供电。

除了可采用LDO保证供电纯净外，还需要考虑：

- ①. 加宽电源走线或采用分割铺铜面来传输电流；
 - ②. 布局上尽量将LDO靠近模块放置；
 - ③. 电源走线避免经过大功率与高感抗器件如磁性线圈。
- 6) 天线接口：天线线路尽量短且顺畅，避免走锐角；注意50Ω阻抗匹配；
 - 7) 避免在K827正下方走线；
 - 8) 模块尽量远离高温气流。

6. Static Electricity Protection / 静电保护

Some components on K827 module are easily damaged by static electricity, which in turn affects the IC circuit and other components. Therefore, you should pay attention to electrostatic protection measures when using it.

- 1) When handling the module, try to wear gloves or finger cots and an anti-static wrist strap that meets the electrostatic protection standards;
- 2) During the process of taking the module, only the edge of the board should be taken, and the solder joints, circuit parts or components should not be directly touched to avoid sweat fingerprints from contaminating the solder joints;
- 3) The module should be protected by a soft protective pad between the module and the module interval during transportation;
- 4) When the module is idle, it should be placed on a soft protective pad (such as anti-static sponge pad, etc.), and do not stack at will;
- 5) The modules should be placed neatly and orderly, with a certain interval between modules to avoid collision with each other;
- 6) The module should be handled with care during use to prevent the module from being damaged by rough operation;
- 7) When powering on, pay attention to the positive and negative poles of the power supply and the voltage to avoid reverse connection and excessive voltage from burning the module;

K827模块上的部分元器件易受静电影响而损坏，进而影响IC电路及其他元件。因此在使用时应注意做好静电保护措施。

- 1) 拿取模块时应尽量戴好手套或者指套以及符合静电防护标准的防静电腕带；
- 2) 模块拿取过程中应只拿取板卡的边缘部位，不能直接接触焊点，线路部分或者元器件，避免汗液指印污染焊点；
- 3) 模块在运输过程中模块与模块间隔之间应该采用软性防护垫进行保护；
- 4) 模块闲置时应放置在软性防护垫上（如防静电海绵垫等），不要随意堆叠；
- 5) 模块摆放应摆放整齐有序，模块之间保持一定间隔，避免相互碰撞；
- 6) 模块在使用过程中应该轻拿轻放，防止粗暴作业损坏模块；
- 7) 上电时，注意电源正负极以及电压，避免反接和电压过高烧毁模块；

4. Application Connection Example / 应用连接示例

In this section, an application connection example of K827 OEM Module is presented via specific schematic diagrams. Per the instruction of these diagrams, you could easily build the communication circuits between K827 OEM Module and other terminals such as PC, GPRS or Bluetooth module, and some other devices with an UART.

本部分以具体电路的形式提供一个K827模块应用连接示例。参照下面的图示，您可以很方便建立K827模块和其他终端（如PC，GPRS模块，蓝牙模块或其他带有UART的设备）之间的通讯电路。

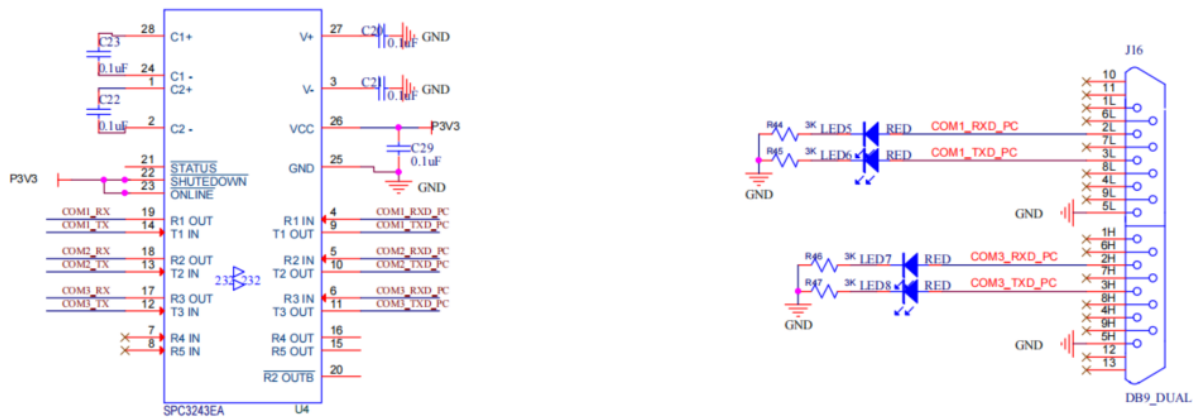

Figure 4. Connections between RS232 COM1, 2, 3 of K827 and Some Other Devices with An UART / K827 RS232 COM1、2、3与其他使用UART接口的设备之间的连接示意

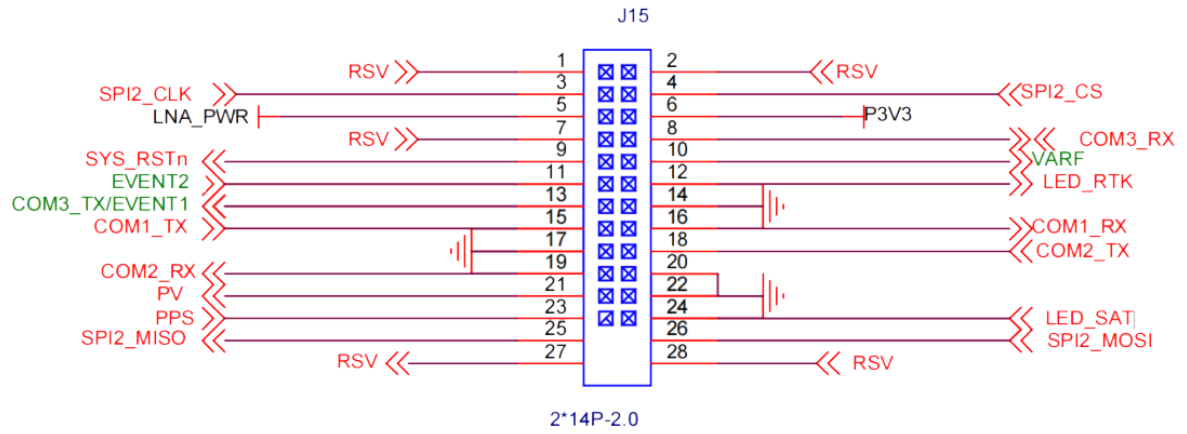

Figure 5. Minimum Hardware Design of K827 / K827 最小硬件设计

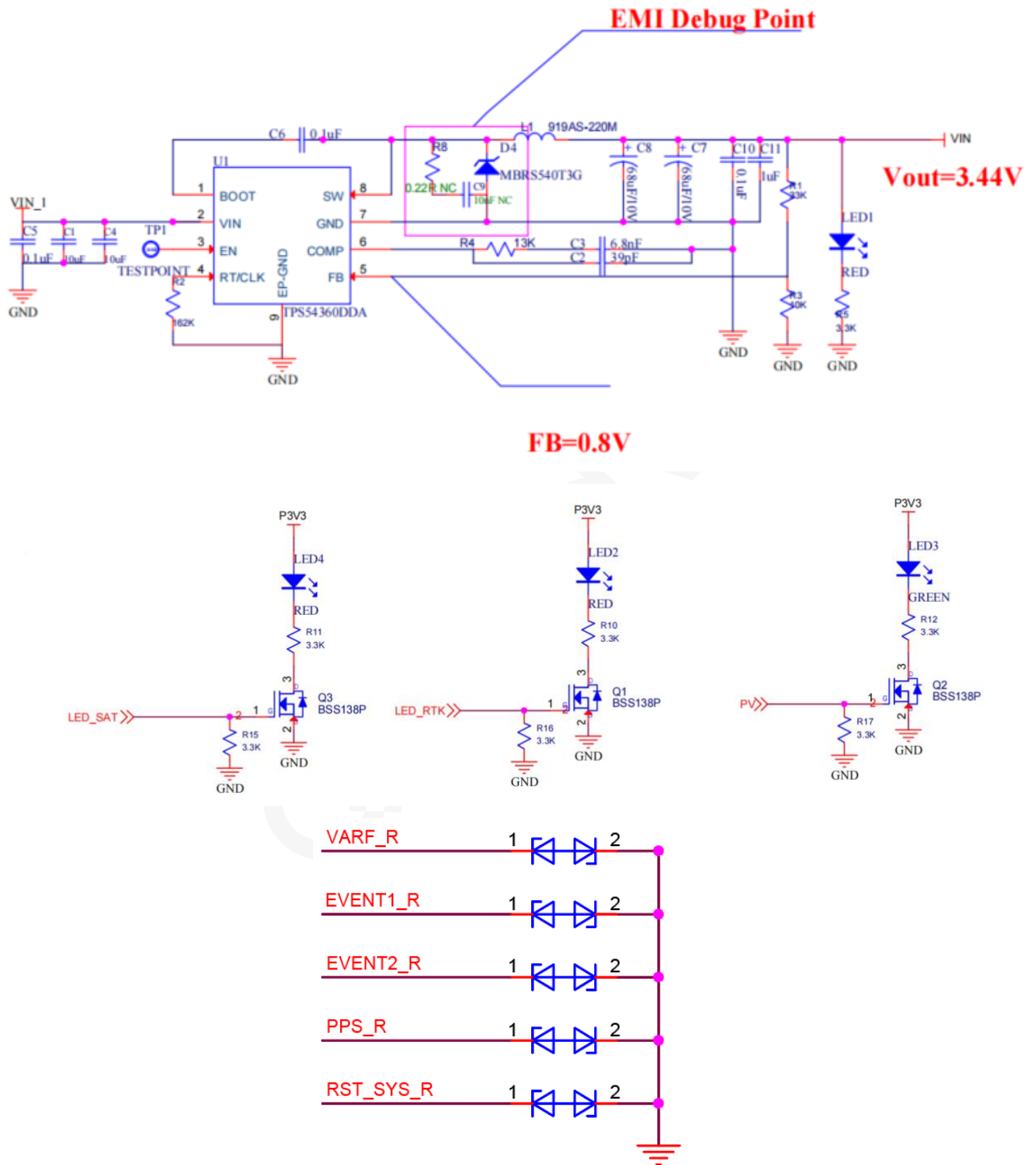

Figure 6. Recommend Design of K827 / K827 推荐硬件设计

©2023, QinNav Technology Ltd. All rights reserved. QinNav is the trademark of QinNav Technology Ltd., registered in People's Republic of China. All other trademarks are the property of their respective owners.

5. Package / 包装

K827 boards are packed in anti-static foam, and 30 pieces of K827 boards are provided in each box.

K827板卡使用防静电泡棉方式包装，每盒提供30片K827板卡。

Table 5. K827 Package Description / K827 包装说明

Project	Description
Board Packaging 模块包装	Number of boxes:1 Pcs/Box 包装盒数量: 1 个/盒
	Number of anti-static foams:1 Pcs/Box 防静电泡棉数量: 1 个/盒
	Board quantity: 30 Slice/Box 板卡数量: 30 片/盒

上海钦天导航技术有限公司

QinNav Technology, LTD.

上海市嘉定区澄浏中路618号1号楼B区6楼

6th Floor, Zone B, Building 1, 618 Chengliu Middle Road, Jiading District, Shanghai

官方网站: www.qinnav.com

邮箱: qinnav@qinnav.com

热线: 400-060-8030



司南导航

QinNav
钦天导航