



PRODUCT SPECIFICATION

产品规范

适用于 For
K803 GNSS 模块
K803 GNSS Module



©2023, QinNav Technology Ltd. All rights reserved. QinNav is the trademark of QinNav Technology Ltd. registered in People's Republic of China. All other trademarks are the property of their respective owners.

REVISION HISTORY / 修订历史

Revision/版本	Modification/更改	Date/日期
1.0	New Release / 新发	2023/8/29

DIRETORY / 目录

REVISION HISTORY / 修订历史.....	2
DIRETORY / 目录.....	3
1. Introduction / 简介.....	4
1.1. Product Characteristics / 产品特性.....	4
2. Size / 尺寸.....	9
3. Pin Arrangement and Definition / 针脚标识和定义.....	11
3.1. Remarks / 说明.....	13
4. Assembling & Repairing Note / 装配及维修说明.....	18
4.1. Module Assembling Note / 模块装配说明.....	18
4.2. Repairing Note / 维修说明.....	19
5. Application Connection Example / 应用连接示例.....	20
6. Package / 包装.....	23
Figures	
Figure 1. K803 Product Photo / K803 实物图.....	9
Figure 2. K803 Dimension View / K803 三视图.....	9
Figure 3. K803 Bottom Section View / K803 底部部分视图.....	10
Figure 4. K803 Includes 82-Pin Pad / K803 包括82连接焊盘.....	11
Figure 5. Furnace Temperature Curve / 炉温曲线.....	18
Figure 6. Connections between RS232 COM1, 2, 3 of K803 and Some Other Devices with An UART / K803 RS232 COM1、2、3与其他使用UART接口的设备之间的连接示意.....	20
Figure 7. Minimum Hardware Design of K803 / K803 最小硬件设计.....	21
Figure 8. Recommend Design of K803 / K803 推荐硬件设计.....	22
Tables	
Table 1. Product Characteristics / 产品特性.....	4
Table 2. Pin Definition of K803 82-Pin Pad / K803 82针脚焊盘的针脚定义.....	11
Table 3. LVCMOS 3.3V Electrical Standard / LVCMOS 3.3V电气标准.....	13
Table 4. LVTTTL 3.3V Electrical Standard / LVTTTL 3.3V电气标准.....	14
Table 5. K803 Package Description / K803 包装说明.....	23

1. Introduction / 简介

K803 GNSS is a full-system and full-frequency RTK positioning module developed by Shanghai QinNav Technology Co., Ltd. based on Quantum III Soc with fully independent intellectual property rights. It supports BDS-2, BDS-3, GPS, GLONASS, Galileo, QZSS, IRNSS and other satellite system signals, contains onboard IMU, supports integrated navigation and is suitable for surveying and mapping, robotics, foundation enhancement and other fields.

K803 GNSS是上海钦天导航技术有限公司基于具有完全自主知识产权的Quantum III开发的全系统全频点RTK定位模块，支持BDS-2、BDS-3、GPS、GLONASS、Galileo、QZSS、IRNSS等卫星系统信号跟踪，板载IMU，支持组合导航，适用于测量测绘、机器人、地基增强等领域。

1.1. Product Characteristics / 产品特性

Table 1. Product Characteristics / 产品特性

Characteristics		K803
Signals 信号	Positioning 定位	GPS: L1C/A, L2P, L2C, L5, L1C
		BDS-2: B1I, B2I, B3I
		BDS-3: B1I, B3I, B1C, B2a, B2b
		GLONASS: G1, G2, G3*
		Galileo: E1, E5b, E5a, E5 AltBoC*, E6c*
		QZSS*: L1C/A, L2C, L5, L1C
		SBAS*: L1C/A, L5
		IRNSS*: L5
Items with * will be adjusted with the version. 带*项会随同版本进行调整。		
Time to First Fix 首次定位时间	Cold Start 冷启动	<20s (Adding Acceleration Capture Module,增加捕获加速模块)
	Hot Start (with RTC)	<10s (Typical,典型)

	热启动 (使用RTC)	
Signal Capture 信号捕获	Reacquisition 失锁重捕	<1s
	Signals Tracking Sensitivity 信号跟踪灵敏度	-155dBm
	Signal Capture Sensitivity 信号捕获灵敏度	-138dBm
Measurement Precision 测量准确度	Pseudo-range Precision 伪距精度	≤10cm
	Carrier Phase Precision 载波相位精度	≤1mm
Accuracy 精度	PPS (RMS) 授时精度	20ns
	SPP Accuracy 标准单点定位精度	H≤1.5m, V≤3m (1σ, PDOP≤4)
	Static Differential Accuracy (Supported by Compass Solution) 静态差分精度 (Compass Solution软件支持)	H:±(2.5+1×10 ⁻⁶ ×D)mm V:±(5.0+1×10 ⁻⁶ ×D)mm D为基线长度 (单位: mm) D-Baseline length (Unit: mm)
	Speed Accuracy 测速精度	≤0.02m/s (1σ, PDOP≤4)
PPP	PPP Convergence Time PPP初始化时间	<15min

	PPP Accuracy PPP精度	H≤10cm, V≤20cm
RTK	RTK Initialization Time RTK初始化时间	<5s (D<10km)
	Initialization Reliability 初始化置信度	>99.9%
	RTK Accuracy RTK精度	H:±(8+10 ⁻⁶ ×D)mm V:±(15+10 ⁻⁶ ×D)mm D为基线长度(单位: mm) D-Baseline length (Unit: mm)
Anti-interference 抗干扰	K803 is built-in narrowband and continuous wave suppression algorithm engine K803 内置窄带和连续波抑制算法引擎	
Inertial Navigation 组合导航	While the GNSS antenna signal is losing lock for 3 seconds, the accuracy maintains at centimeter level. While the GNSS antenna signal is losing lock for 10 seconds, the accuracy maintains at meter level. GNSS天线信号失锁 3s, 精度保持cm级 GNSS天线信号失锁 10s, 精度保持m级	
IMU	Gyroscope 陀螺仪	Measurement ranges 量程: ±125°/s
		Zero-biased stability 零偏稳定性: 10°/h
		Angular random walk 角度随机游走: 0.3°/sqrt(h)
	Measurement ranges	

	Accelerometer 加速度计	量程: $\pm 4g$
		Bias instability 零偏稳定性: 70ug
		Velocity random walk 速度随机游走: 0.16m/s/sqrt(h)
Data Rates 数据速率	Measurements & Position 测量&定位	Max 20Hz (Optional, 选配项)
	RTK: Positioning RTK: 定位	Max 20Hz (Optional, 选配项)
	IMU	Max 50Hz (Optional, 选配项)
Data Formats 输出数据格式	NMEA-0183	GPGGA, GPGSV, GPGLL, GPGSA, GPGST, GPHDT, GPRMC, GPVTG, GPZDA etc.
	ComNav Binary (CNB) 司南二进制格式	ComNav Self-Defined Binary 司南自定义二进制
	CMR(GPS)	CMROBS, CMRREF
	RTCM2.X	RTCM1, RTCM3, RTCM31
	RTCM3.X	1004~1008,1012,1019,1020,1033,1042,1045/1046, 1230 MSM3~MSM7:1073~1077,1083~1087,1123~1127,1093~1097
Electrical 电气特性	Voltage 供电电压	+ 3.3V~3.45V DC
	Power Consumption 功耗	0.95W
Environmental	Operating Temperature	-40°C~+85°C

©2023, QinNav Technology Ltd. All rights reserved. QinNav is the trademark of QinNav Technology Ltd., registered in People's Republic of China. All other trademarks are the property of their respective owners.

环境要求	工作温度	
	Storage Temperature 储存温度	-55°C~+95°C
Antenna Interface 天线接口	Impedance Matching 阻抗匹配	50Ω
	Antenna Power 天线供电电压	External 外部供电: +3.3V~+5V @ (0-100) mA
	Antenna Gain 天线增益	20~35dB
Hardware Interface 硬件接口		UARTx4, PPSx1, EVENTx2, SPIx1
Physical 物理参数	Size 尺寸	30mm×30mm×3.2mm
	Weight 重量	6.6g
	Flatness 平整度	≤0.1mm
	Package 封装	LGA (82PIN)

2. Size / 尺寸

In this section, product photo, three-side views and the dimension of K803 is provided for customers' further hardware design and installation.

本节提供了K803的实物图，三视图和对应的物理尺寸，便于用户进一步系统硬件设计和安装。



Figure 1. K803 Product Photo / K803 实物图

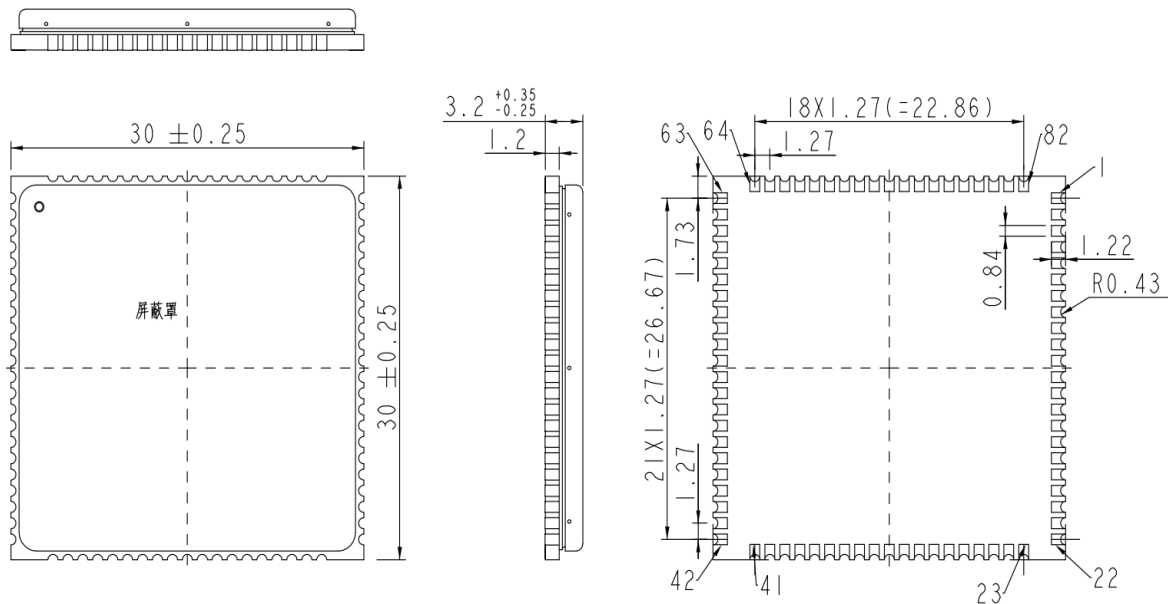

Figure 2. K803 Dimension View / K803 三视图

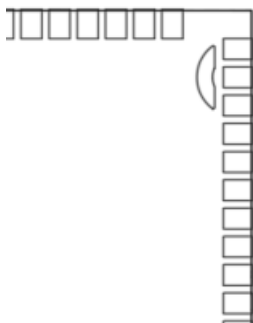

Figure 3. K803 Bottom Section View / K803 底部部分视图

Note: Because there is a half-moon window exposed tin position near the bottom of K803 module 62Pin, it is recommended that the pad should not be expanded outward when the user is packaged, otherwise it will be short-circuited.

注意：因为K803模块62Pin附近底部有半月形开窗露锡位置，建议用户封装时，焊盘尽量不要往外扩，否则会短路。

3. Pin Arrangement and Definition / 针脚标识和定义

K803 is surface-mount OEM Module which integrates 82 Pin (pitch 1.27mm).

K803包括82Pin, 表贴式模块 (pitch 1.27mm) 。

	RSV 82	RSV 81	RSV 80	RSV 79	RSV 78	RSV 77	RSV 76	RSV 75	RSV 74	RSV 73	RSV 72	RSV 71	RSV 70	RSV 69	RSV 68	RSV 67	RSV 66	RSV 65	RSV 64	
1	GND																			GND 63
2	RSV																			ANT_IN 62
3	RSV																			ANT_PWR 61
4	RSV																			RSV 60
5	EVENT2																			ANT_SHORT 59
6	GND																			GND 58
7	RSV																			RST_N 57
8	RSV																			EVENT1 56
9	V_BACKUP																			PPS 55
10	GND																			GND 54
11	PVT_STAT																			COM4_RXD 53
12	GPIO																			COM4_TXD 52
13	RSV																			COM3_RXD 51
14	FRESET_N																			COM3_TXD 50
15	RSV																			COM2_RXD 49
16	RTK_STAT																			COM2_TXD 48
17	GND																			COM1_RXD 47
18	SPI_MISO																			COM1_TXD 46
19	SPI_MOSI																			GND 45
20	SPI_CLK																			GND 44
21	SPI_CS																			VIN 43
22	RSV																			VIN 42
	GND 23	VARF 24	ATOM 25	GND 26	RSV 27	RSV 28	RSV 29	RSV 30	RSV 31	RSV 32	RSV 33	RSV 34	RSV 35	RSV 36	RSV 37	RSV 38	RSV 39	RSV 40	RSV 41	

Figure 4. K803 Includes 82-Pin Pad / K803 包括82连接焊盘

Table 2. Pin Definition of K803 82-Pin Pad / K803 82针脚焊盘的针脚定义

Pin	Signal	Type	Description	
1	GND	GND	Ground Reference	参考地

©2023, QinNav Technology Ltd. All rights reserved. QinNav is the trademark of QinNav Technology Ltd., registered in People's Republic of China. All other trademarks are the property of their respective owners.

Pin	Signal	Type	Description	
2~4	RSV	/	Reserve (Float)	保留管脚 (悬空)
5	EVENT2	I	Event Mark	外部事件输入
6	GND	GND	Ground Reference	参考地
7~8	RSV	/	Reserve (Float)	保留管脚 (悬空)
9	V_BACKUP	PWR	Power Supply for Internal RTC	外接RTC电池
10	GND	GND	Ground Reference	参考地
11	PVT_STAT	O	PVT Status	搜星时, 模块搜星数与高电平脉冲数一致; 不搜星时, 5S输出一次高电平
12	GPIO	I/O	General-Purpose Input/Output	通用IO
13	RSV	/	Reserve (Float)	保留管脚 (悬空)
14	FRESET_N	I	Reset to Factory Mode (Active Low)	复位为出厂模式 (低电平有效)
15	RSV	/	Reserve (Float)	保留管脚 (悬空)
16	RTK_STAT	O	RTK Data LED Indicator	在接收或发送差分信号时会输出高电平脉冲, 其他状态输出低电平
17	GND	GND	Ground Reference	参考地
18	SPI_MISO	I	SPI_MISO	SPI主输入从输出信号
19	SPI_MOSI	O	SPI_MOSI	SPI主输出从输入信号
20	SPI_CLK	O	SPI_CLK	SPI总线时钟信号
21	SPI_CS	O	SPI_CS	SPI总线片选信号
22	RSV	/	Reserve (Float)	保留管脚 (悬空)
23	GND	GND	Ground Reference	参考地
24	VARF	O	Square Wave Output	方波输出
25	ATOM*	I	Atomic Clock Input	原子钟输入
26	GND	GND	Ground Reference	参考地
27~41	RSV	/	Reserve (Float)	保留管脚 (悬空)
42~43	VIN	PWR	DC Power Supply for Module (3.3V)	模块供电电源 (+3.3V)
44~45	GND	GND	Ground Reference	参考地
46	COM1_TXD	O	Transmitted Data for COM1 Output	串口1输出信号
47	COM1_RXD	I	Received Data for COM1 Input	串口1输入信号
48	COM2_TXD	O	Transmitted Data for COM2 Output	串口2输出信号
49	COM2_RXD	I	Received Data for COM2 Input	串口2输入信号
50	COM3_TXD	O	Transmitted Data for COM3 Output	串口3输出信号
51	COM3_RXD	I	Received Data for COM3 Input	串口3输入信号
52	COM4_TXD	O	Transmitted Data for COM4 Output	串口4输出信号
53	COM4_RXD	I	Received Data for COM4 Input	串口4输入信号
54	GND	GND	Ground Reference	参考地
55	PPS	O	Pulse Output Synchronized to OEM Time	同步卫星时间脉冲

Pin	Signal	Type	Description	
56	EVENT1	I	Event Mark	外部事件输入
57	RST_N	I	Quick Reset without Clearing User Configuration (Low Active)	快速复位, 不清除用户配置 (低电平有效)
58	GND	PWR	Ground Reference	参考地
59	ANT_SHORT	O	Short Indication of Antenna (Low Active)	天线短路指示(低电平有效)
60	RSV	/	Reserve (Float)	保留管脚 (悬空)
61	ANT_PWR	PWR	Power Supply for External GNSS Antenna LNA	外部GNSS天线供电
62	ANT_IN	I	GNSS Antenna	GNSS天线输入
63	GND	GND	Ground Reference	参考地
64~82	RSV	/	Reserve (Float)	保留管脚 (悬空)
Items with * will be adjusted with the version. 带*项会随同版本进行调整。				

3.1. Remarks / 说明

1. Electrical Characteristics / 电气特性

COM1/2/3/4(TX&RX), SPI, ANT_SHORT, PVT_STAT, FRESET_N, RTK_STAT, RST_N, PPS EVENT1 and EVENT2 are LVCMOS 3.3V level, All these signals are LVCMOS/LVTTL 3.3V compatible.

COM1/2/3/4 (TX&RX) , SPI, ANT_SHORT, PVT_STAT, FRESET_N, RTK_STAT, PGMEN, RST_N, PPS, EVENT1和EVENT2为LVCMOS 3.3V 电平, 所有这些信号均兼容LVCMOS / LVTTL 3.3V。

Table 3. LVCMOS 3.3V Electrical Standard / LVCMOS 3.3V电气标准

Symbols 符号	Description 描述	Min 最小	Max 最大
V _{IH}	Input high voltage 输入高电压	2.0V	VCC+0.3V
V _{IL}	Input low voltage 输入低电压	-0.3V	0.8V
V _{OH}	High-level output voltage 高电平输出电压	VCC-0.4V	--
V _{OL}	Low-level output voltage 低电平输出电压	--	0.41V
I _{OH}	Sourcing current 拉电流		8mA
I _{OL}	Sinking current 灌电流		8mA

Table 4. LVTTTL 3.3V Electrical Standard / LVTTTL 3.3V电气标准

Symbols 符号	Description 描述	Min 最小	Max 最大
V _{IH}	Input high voltage 输入高电压	2.0V	VCC+0.3V
V _{IL}	Input low voltage 输入低电压	-0.3V	0.8V
V _{OH}	High-level output voltage 高电平输出电压	VCC-0.4V	--
V _{OL}	Low-level output voltage 低电平输出电压	--	0.41V
I _{OH}	Sourcing current 拉电流		8mA
I _{OL}	Sinking current 灌电流		8mA

2. Can withstand Voltage Range / 能承受的电压范围

The signal with the maximum voltage range from -0.3V to 3.6V is as follows: COM1/2/3/4 (TX&RX), SPI, ANT_SHORT, JTAG, PVT_STAT, FRESET_N, RTK_STAT, PGMEN, RST_N, PPS, EVENT1 and EVENT2.

所能承受电压的最大值范围是-0.3V~3.6V的信号如下：COM1/2/3/4（TX&RX），SPI，ANT_SHORT，JTAG，PVT_STAT，FRESET_N，RTK_STAT，PGMEN，RST_N，PPS，EVENT1和EVENT2。

3. Supply Voltage / 供电电压

VIN main power supply, voltage range: 3.3V~3.45V (DC), voltage ripple and spikes require less than 50mV. K803: ANT_PWR, voltage range: 3.3V ~ 5.5V (DC), voltage ripple and spikes require less than 50mV. V_BACKUP operating voltage 1.8V~3.6V, voltage ripple and spike pulse requirements are less than 30mV; When charging the Farrah capacitor, V_BACKUP voltage reference circuit, voltage ripple and spike pulse requirements are less than 30mV.

VIN主供电电源，电压范围：3.3V~3.45V（直流），电压纹波和尖峰脉冲要求小于50mV。K803：ANT_PWR，电压范围：3.3V~5.5V（直流），电压纹波和尖峰脉冲要求小于50mV。V_BACKUP工作电压1.8V~3.6V，电压纹波和尖峰脉冲要求小于30mV；给法拉电容充电时，V_BACKUP电压参考电路，电压纹波和尖峰脉冲要求小于30mV。

4. Add Surge Protection / 增加浪涌保护

In order to effectively protect against lightning strikes and surges, and prevent damage to the feed current limiting chip inside the module, it is recommended that users supply power to the antenna from outside the module and increase the surge protection function.

If you need to feed the antenna from the outside, it is recommended to use a high-voltage, high-power feeder chip; or add high-power protection devices such as gas discharge tubes, varistors, and TVS tubes to the feeder circuit.

为了有效防雷击、防浪涌，防止模块内部的馈电限流芯片损坏,建议用户从模块外部给天线供电并增加浪涌保护功能。

如需从外部为天线馈电，建议选用高耐压、大功率的馈电芯片；或在馈电电路上增设气体放电管、压敏电阻、TVS管等大功率的防护器件。

5. Antenna Short Circuit Description / 天线短路说明

When using the internal feed of the board, the following situations will occur:

- 1) When the antenna is normal, Pin 59 outputs high level;
- 2) When the antenna is short circuited, Pin 59 outputs low level

当使用板卡内部馈电时，会出现如下情况：

- 1) 天线正常时，Pin 59输出高电平；
- 2) 天线短路时，Pin 59输出低电平；

6. Hardware Integration Considerations / 硬件集成注意事项

- 1) VCC power-on has a good monotonicity, and the initial level is lower than 0.4V, and the upstroke and ringing are guaranteed within the range of 5% VCC;
- 2) Use the VCC pin to provide a reliable power supply and all GND pins of the module are grounded;
- 3) Connect the ANT_IN signal to the antenna, pay attention to the 50Ω impedance matching of the line;
- 4) The ANT_PWR pin is connected to +3.3~5.5V voltage, and then provides +3.3~5.5V feed to the antenna through the ANT_IN pin;
- 5) The module reset pin FRESET_N is for restoring the factory settings of the module, and RST_N is for quick reset. Please connect it correctly to ensure that the module can be reset reliably;
- 6) Special attention should be paid to:

Power supply: The guarantee of stable and low ripple power supply, the peak-to-peak value of the ripple voltage is preferably not higher than 50mVpp. It is recommended to use a power chip with a current output capacity greater than 2A to supply power to the module.

In addition to using LDO to ensure the power supply is pure, it is also necessary to consider:

- ①. Widening the power traces or using split copper surfaces to transmit current;
 - ②. Place the LDO as close to the module as possible in the layout;
 - ③. Avoid the power traces passing through high power with high inductance devices such as magnetic coils.
- 7) Antenna interface: The antenna line is as short and smooth as possible, avoiding acute angles; pay attention to 50Ω impedance matching;

- 8) Avoid wiring directly under K803;
 - 9) The module is as far away from the high temperature airflow as possible.
- 1) VCC上电具有良好的单调性, 且起始电平低于0.4V, 上冲与振铃保障在5%VCC范围内;
 - 2) 用VCC引脚提供可靠的电源且模块所有GND引脚接地;
 - 3) 连接ANT_IN信号至天线,注意线路50Ω阻抗匹配;
 - 4) ANT_PWR脚接入+3.3~5.5V电压, 再经由ANT_IN脚对天线提供+3.3~5.5V的馈电;
 - 5) 模块复位引脚FRESET_N为恢复模块出厂设置, RST_N为快速复位, 请正确连接以保证模块可以可靠复位;
 - 6) 在设计中应特别注意:
供电: 稳定及低纹波电源的保证, 纹波电压峰峰值最好不高于50mVpp。建议采用电流输出能力大于2A的电源芯片给模块供电。
除了可采用LDO保证供电纯净外, 还需要考虑:
 - ①. 加宽电源走线或采用分割铺铜面来传输电流;
 - ②. 布局上尽量将LDO靠近模块放置;
 - ③. 电源走线避免经过大功率与高感抗器件如磁性线圈。
 - 7) 天线接口: 天线线路尽量短且顺畅, 避免走锐角; 注意50Ω阻抗匹配;
 - 8) 避免在K803正下方走线;
 - 9) 模块尽量远离高温气流。

7. Static Electricity Protection / 静电保护

Some components on K803 module are easily damaged by static electricity, which in turn affects the IC circuit and other components. Therefore, you should pay attention to electrostatic protection measures when using it.

- 1) When handling the module, try to wear gloves or finger cots and an anti-static wrist strap that meets the electrostatic protection standards;
- 2) During the process of taking the module, only the edge of the board should be taken, and the solder joints, circuit parts or components should not be directly touched to avoid sweat fingerprints from contaminating the solder joints;
- 3) The module should be protected by a soft protective pad between the module and the module interval during transportation;
- 4) When the module is idle, it should be placed on a soft protective pad (such as anti-static sponge pad, etc.), and do not stack at will;
- 5) The modules should be placed neatly and orderly, with a certain interval between modules to avoid collision with each other;
- 6) The module should be handled with care during use to prevent the module from being damaged by rough operation;
- 7) When powering on, pay attention to the positive and negative poles of the power supply and the voltage to avoid reverse connection and excessive voltage from burning the module;
- 8) When soldering the module to the motherboard, please ensure that the GND is soldered first, and then the ANT_IN pin;
- 9) When handling ANT_IN pin, do not touch any live capacitance or material (e.g., surface mount antenna, coaxial cable, wire iron, etc.) to avoid damage to the ANT_IN pin by the charge generated or stored by said capacitor or material;

10) Please make sure to solder the ANT_IN pin with an electrical protection iron.

K803模块上的部分元器件易受静电影响而损坏，进而影响IC电路及其他元件。因此在使用时应注意做好静电保护措施。

- 1) 拿取模块时应尽量戴好手套或者指套以及符合静电防护标准的防静电腕带；
- 2) 模块拿取过程中应只拿取板卡的边缘部位，不能直接接触焊点，线路部分或者元器件，避免汗液指印污染焊点；
- 3) 模块在运输过程中模块与模块间隔之间应该采用软性防护垫进行保护；
- 4) 模块闲置时应放置在软性防护垫上（如防静电海绵垫等），不要随意堆叠；
- 5) 模块摆放应摆放整齐有序，模块之间保持一定间隔，避免相互碰撞；
- 6) 模块在使用过程中应该轻拿轻放，防止粗暴作业损坏模块；
- 7) 上电时，注意电源正负极以及电压，避免反接和电压过高烧毁模块；
- 8) 将模块焊接到主板时，请确保GND先焊接，然后再焊接ANT_IN引脚；
- 9) 处理ANT_IN引脚时，请不要接触任何带电电容或材料（例如表贴天线、同轴电缆、电烙铁等），以免所述电容或材料所产生或存储的电荷损坏ANT_IN引脚；
- 10) 请确保使用带电保护的电烙铁焊接ANT_IN引脚。

4. Assembling & Repairing Note / 装配及维修说明

4.1. Module Assembling Note / 模块装配说明

K803 is surface mounted, SMT welding is recommended for assembly.

K803为表贴式模块，推荐使用SMT的焊接方式进行装配。

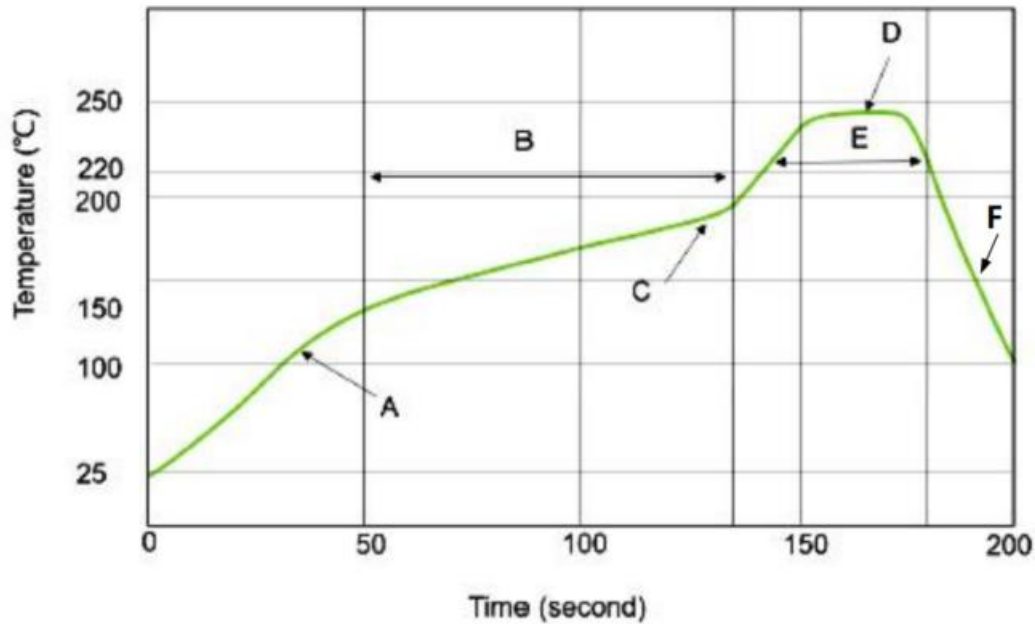

Figure 5. Furnace Temperature Curve / 炉温曲线

The process temperature limits are as follows:

- A: Heating Zone: Rising Slope: 1 ~ 3°C / sec
- B: Constant Temperature Zone: Range: 150 ~ 190 °C Time: 80 ~ 110 S
- C: Constant Temperature→Reflow Zone: Rising Slope: 1 ~ 3°C / sec
- D: Peak Temperature: 235 ~ 245°C
- E: Reflow Zone: Range: Over 220°C Time: 50 ~ 80 S
- F: Descent Slope: -5°C ~ -1°C / sec

制程温度界限如下：

- A: 升温区：斜率：1 ~ 3°C / sec
- B: 恒温区：150 ~ 190°C 时间：80 ~ 110S
- C: 恒温→回流区：斜率：1 ~ 3°C / sec
- D: 峰值温度：235 ~ 245°C
- E: 回流区：大于220°C 时间：50 ~ 80S
- F: 下降斜率：-5 ~ -1°C / sec

In order to prevent the module from being damaged by repeated heating, it is recommended to place the module after finishing the first side of PCB board.

为避免模块因反复受热而损坏，建议在完成PCB板第一面的回流焊之后再贴模块。

4.2. Repairing Note / 维修说明

When disassembling the module, it is suggested using a BGA welding bench. Please use correct air tuyere and choose certain temperature curve. Keep peak temperature under 245°C, rising slope under 3°C /s.

拆卸模块时，请使用BGA返修台，选择适合尺寸的风嘴并使用合适的温度曲线，最高温度不超过245°C，升温斜率不超过3°C/s。

5. Application Connection Example / 应用连接示例

In this section, an application connection example of K803 OEM Module is presented via specific schematic diagrams. Per the instruction of these diagrams, you could easily build the communication circuits between K803 OEM Module and other terminals such as PC, GPRS or Bluetooth module, and some other devices with an UART.

本部分以具体电路的形式提供一个K803模块应用连接示例。参照下面的图示，您可以很方便建立K803模块和其他终端（如PC，GPRS模块，蓝牙模块或其他带有UART的设备）之间的通讯电路。

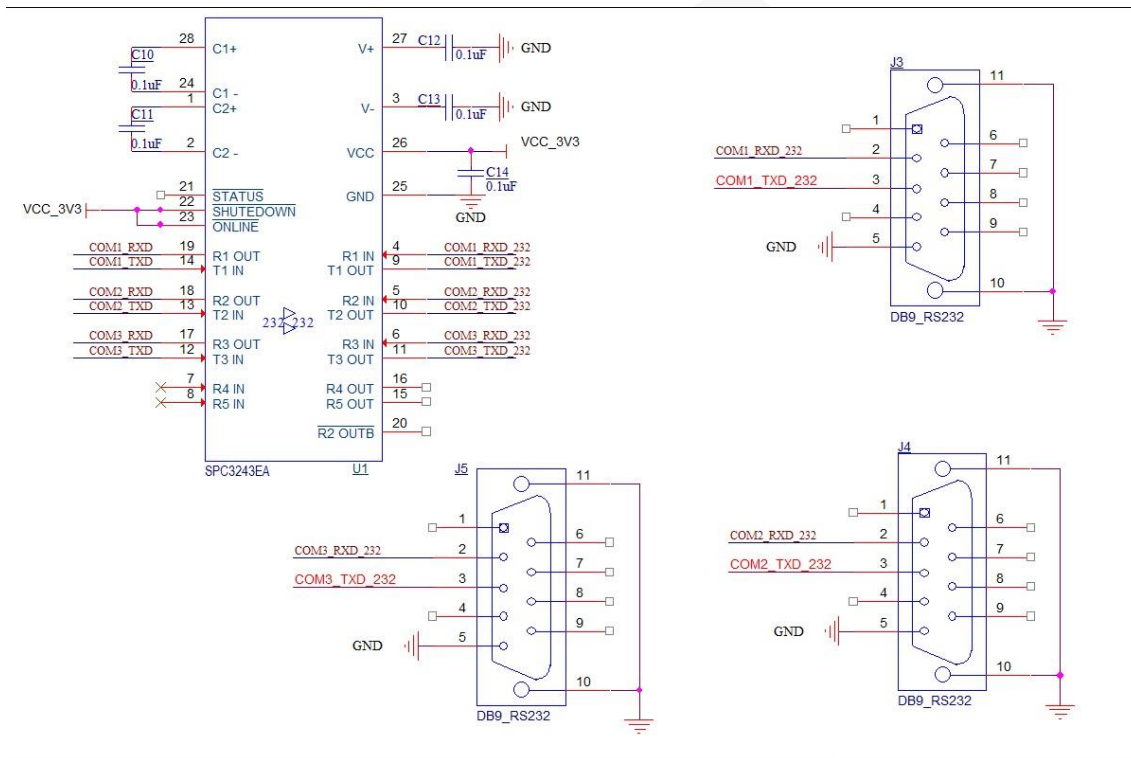

Figure 6. Connections between RS232 COM1, 2, 3 of K803 and Some Other Devices with An UART / K803 RS232 COM1, 2, 3与其他使用UART接口的设备之间的连接示意

©2023, QinNav Technology Ltd. All rights reserved. QinNav is the trademark of QinNav Technology Ltd., registered in People's Republic of China. All other trademarks are the property of their respective owners.

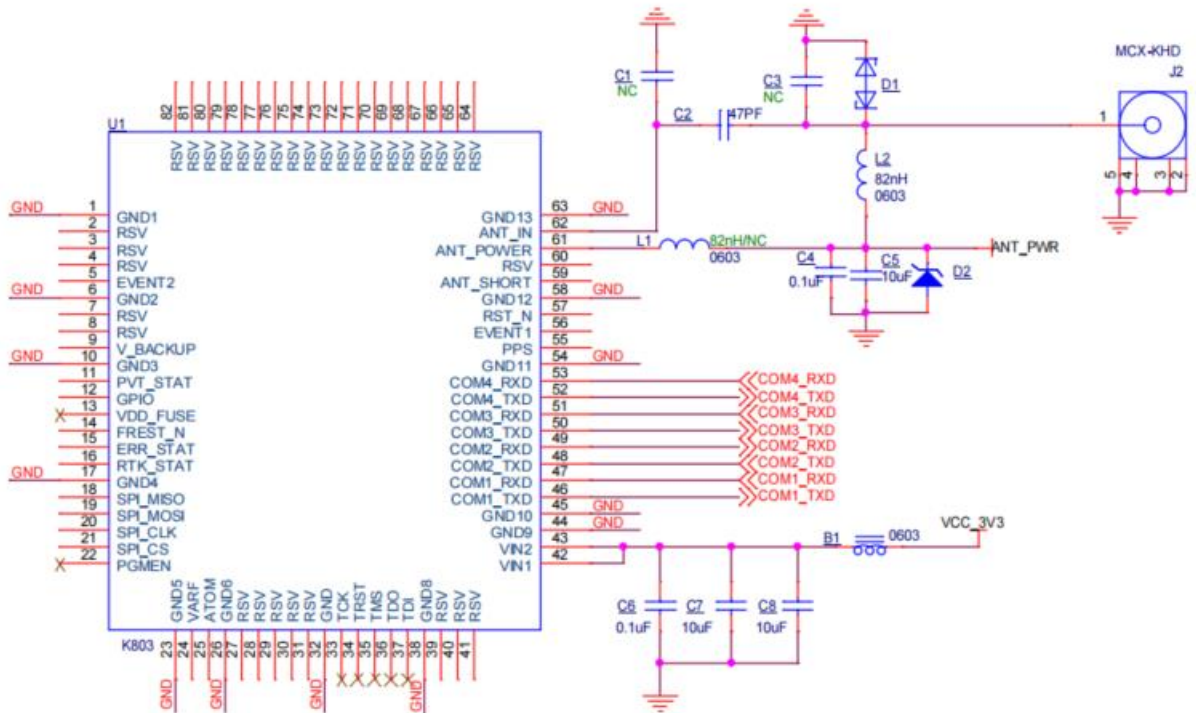

Figure 7. Minimum Hardware Design of K803 / K803 最小硬件设计

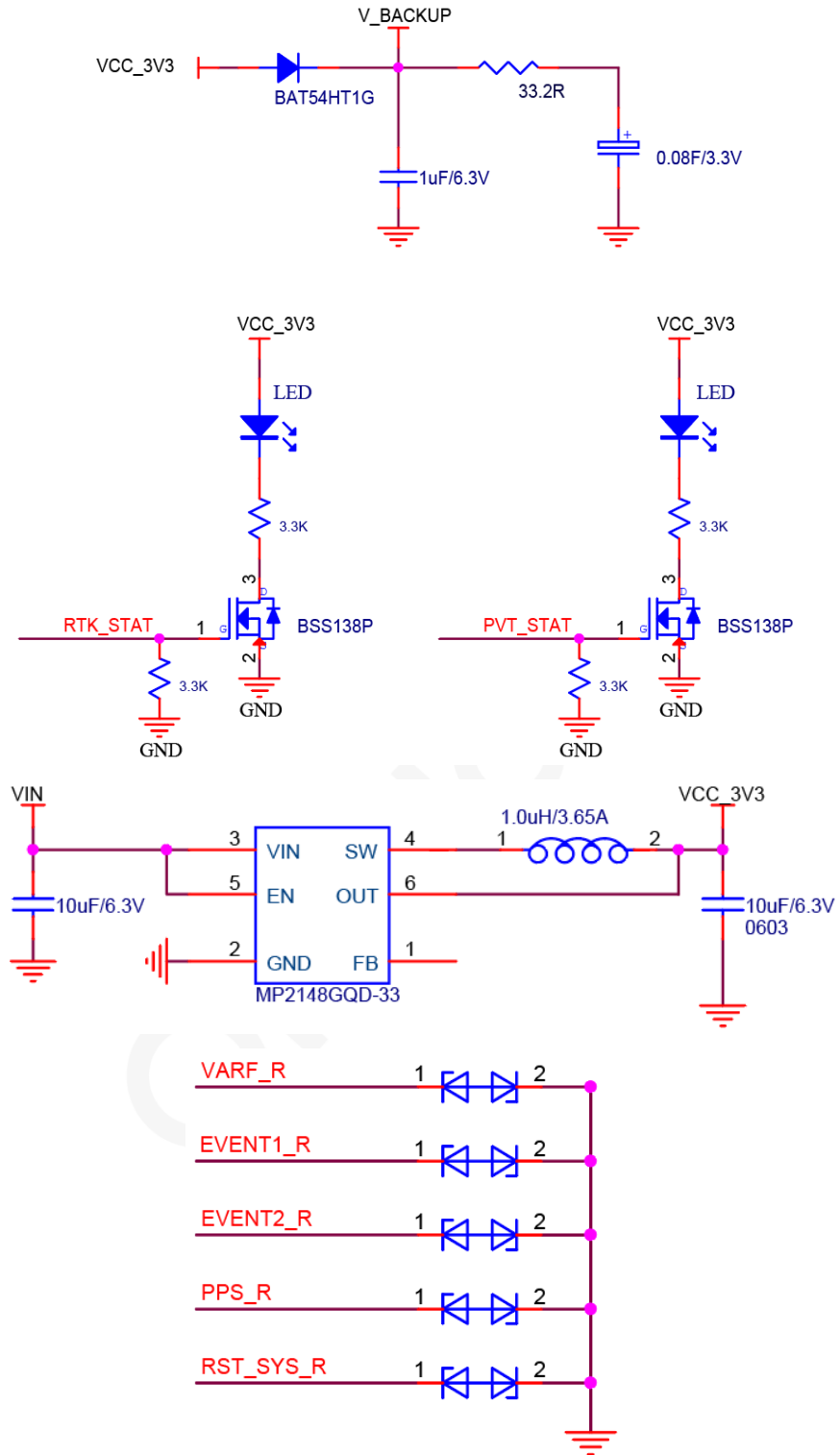

Figure 8. Recommend Design of K803 / K803 推荐硬件设计

©2023, QinNav Technology Ltd. All rights reserved. QinNav is the trademark of QinNav Technology Ltd., registered in People's Republic of China. All other trademarks are the property of their respective owners.

6. Package / 包装

K803 modules are packed by pallet, and 100 pieces of K803 modules are provided in each box.

K803模块使用托盘方式包装，每盒提供100片K803模块。

Table 5. K803 Package Description / K803 包装说明

Project	Description
Module Packaging 模块包装	Number of ESD vacuum bags: 1 Pcs/Box 防静电真空袋数量: 1 个/盒
	Humidity card number: 1 Pcs/Box 湿度卡数量: 1 个/盒
	Quantity of desiccant: 1 Pcs/Box 干燥剂数量: 1 个/盒
	Number of trays: 6 Pcs/Box (Note: Modules are not stored on the top tray) 托盘数量: 6 个/盒 (注: 最上面的托盘上不存放模块)
	Number of modules in each tray: 20 Slice/Plate 每个托盘中模块数量: 20 片/盘
	Module quantity: 100 Slice/Box 模块数量: 100 片/盒



上海钦天导航技术有限公司

QinNav Technology, LTD.

上海市嘉定区澄浏中路618号1号楼B区6楼

6th Floor, Zone B, Building 1, 618 Chengliu Middle Road, Jiading District, Shanghai

官方网站: www.qinnav.com

邮箱: qinnav@qinnav.com

热线: 400-060-8030



©2023, QinNav Technology Ltd. All rights reserved. QinNav is the trademark of QinNav Technology Ltd., registered in People's Republic of China. All other trademarks are the property of their respective owners.